



Front Load



Side Load

**Item #:** \_\_\_\_\_ **Qty #:** \_\_\_\_\_  
**Model #:** \_\_\_\_\_  
**Project #:** \_\_\_\_\_

**FEATURES:**

- Curved top design.
- Heavy duty welded construction with 6 cross supports.
- Nickel chrome plated steel wire.
- Heavy duty 5" stem bolted casters.
- 500 lb. capacity.

**CONSTRUCTION:**

- Fully welded 1" square tubing ladder assembly.
- Angles are 1" x 1 1/2" x 20" on front load pan rack and 1" x 1 1/2" x 17 3/4" on side load pan rack.

**MATERIAL:**

- 6063-T52 extruded aluminum angles, upright tubing, and support pieces.
- Nickel chrome plated steel wire.

MODEL #	Description	Pan Capacity	Shelf Spacing	Overall Size L x W x H	Weight
WR36	Front Load	36	1 1/2"	20 1/4" x 25" x 69 1/4"	72 lbs.
WR36S	Side Load	36	1 1/2"	28 1/4" x 19 1/8" x 69 1/4"	64 lbs.

# DIMENSIONS and SPECIFICATIONS

TOL  $\pm$  .500"

ALL DIMENSIONS ARE TYPICAL

## Front Load

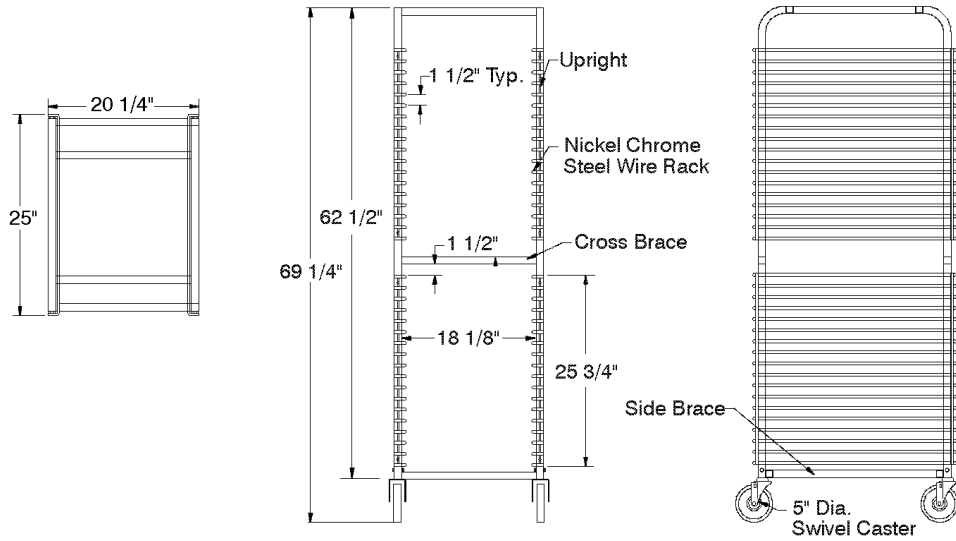

## Side Load

