



STAINLESS STEEL & PLASTIC UTILITY CARTS



150 lb. Capacity

FEATURES:

Knock Down Unit.
4" Swivel Casters
Sound dampening pads affixed to shelving bottom.
Adjustable shelves furnished with 1 1/4" x 1" square die embossed NO-DRIP countertop edge with 1/2" return on four sides.

CONSTRUCTION:

Unit assembles using tapered split sleeves.
Set of four 4" swivel casters includes two casters with brakes and 4 donut bumpers.

MATERIAL:

SHELVES: Heavy gauge stainless steel.
TUBING: chrome post.

Model #	A	B	Length	Width	Wt.
UC-3-1827	18"	27"	34 1/2"	18"	27 lbs.
UC-3-2433	24"	33"	40 1/2"	24"	35 lbs.

Item #: _____ Qty #: _____

Model #: _____

Project #: _____



FEATURES:

K.D. Unit.
4" Swivel Casters, 2 with brakes.
3 shelves with 1/4" retaining lip all sides.
150 lb. weight capacity.
Easy to assemble.

CONSTRUCTION:

Injection molded thermoplastic.

MATERIAL:

Black thermoplastic.

MODEL #	Length	Width	Wt.
PUC-1824	26 1/2"	18"	28 lbs.

DETAILS and SPECIFICATIONS

TOL ± .500"

ALL DIMENSIONS ARE TYPICAL

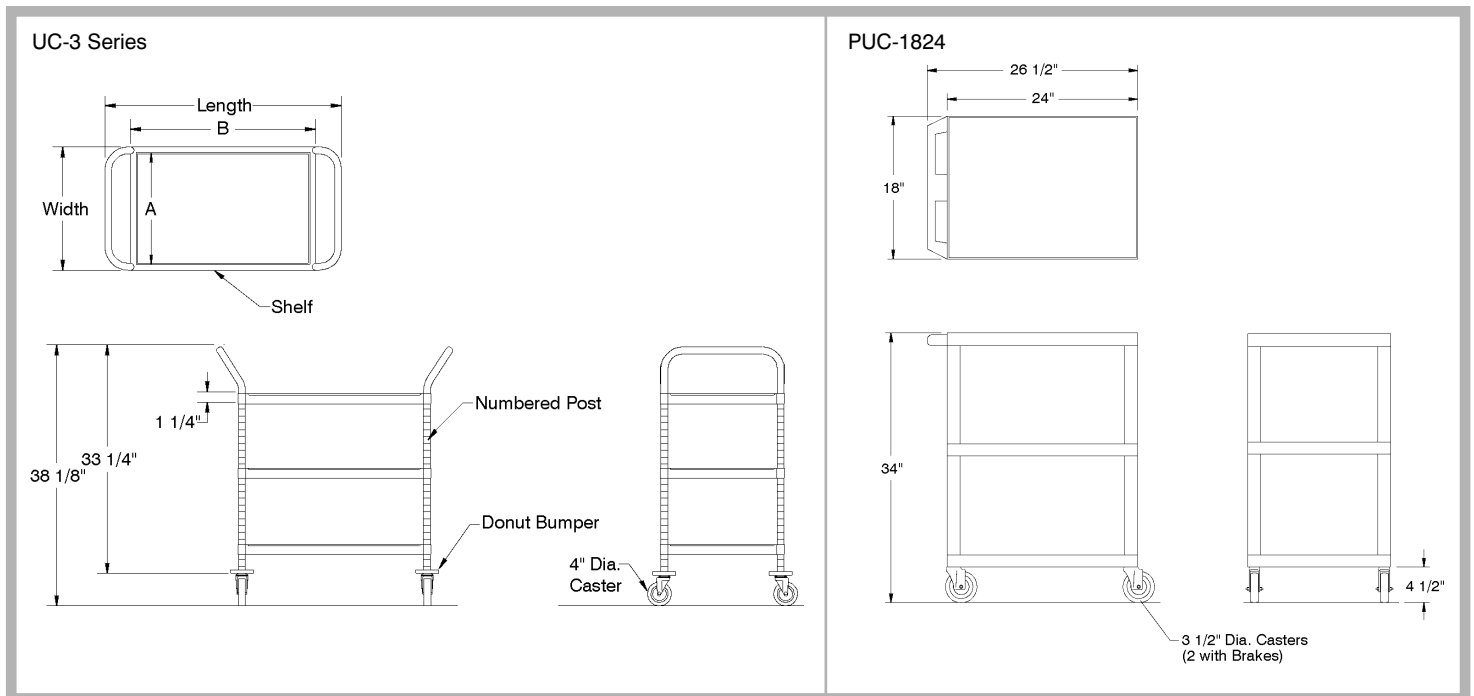

Commercial Home Products Collection
CALL TOLL FREE: 866-799-0106 • TOLL FREE FAX: 866-799-0249 • email: info@advancetabcohome.com
200 Heartland Blvd. Edgewood New York 11717

